



USER GUIDE
MS-RS-675
MS-RS-1220



MUCK STOPPER

PRODUCT SPECIFICATION SHEET

MUCKSTOPPER RS 675

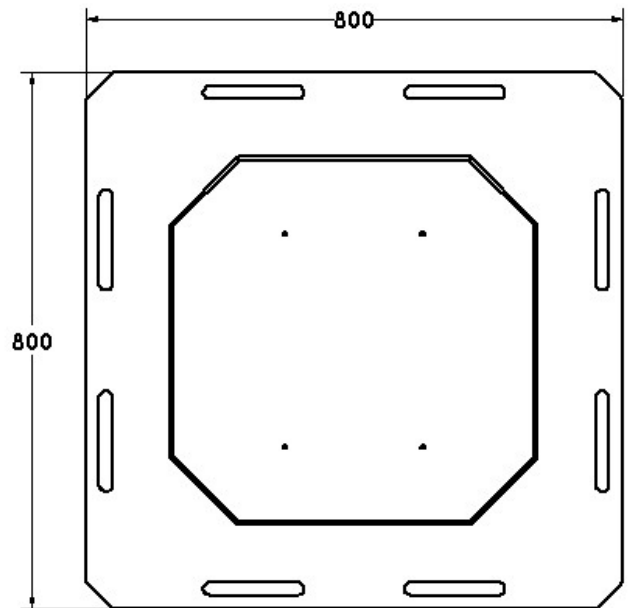

Name
MuckStopper RS-675

Code
MS-RS-675

Description
The MuckStopper RS-675 is a silt barrier with a removable lid designed for 600mm and 675mm sewer manholes installed in roads.

Frame Size
800mm x 800mm

Lid Size
548mm x 548mm

Weight
10.1KG

Loading
PEDESTRIAN ONLY

Material
GALVANISED STEEL

Compatibility
Will work with any brand of manhole cover and frame

Overview

We have designed the MuckStopper RS 675 to solve the challenge of mud and silt entering 600mm x 600mm and 675mm x 675mm manhole covers and blocking the drainage system below. This barrier protects the drains from silt whilst allowing access to the chamber below.

Rugged and easy to fit, we designed MuckStopper RS 675 for you to install beneath the manhole cover and frame. It has a robust, silt-tight, removable lid to allow chamber access but prevent the ingress of silt and dirt.

MUCK STOPPER

PRODUCT SPECIFICATION SHEET

MUCKSTOPPER RS 1220

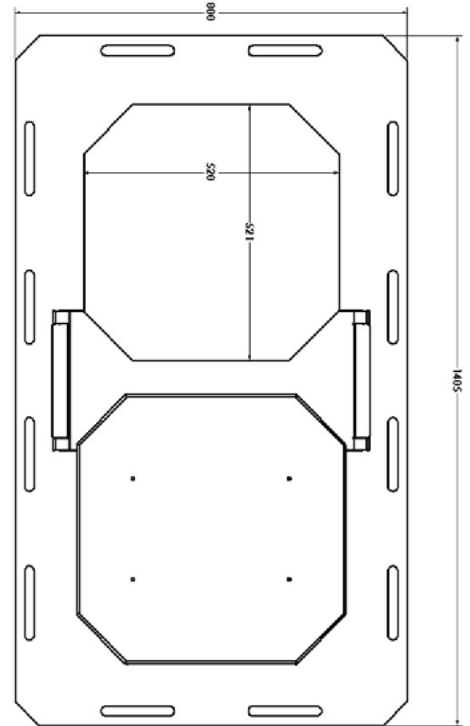

Name
MuckStopper RS-1220

Code
MS-RS-1220

Description
The MuckStopper RS-1220 is a silt barrier with removable lids designed for 1200mm and 1220mm sewer manholes installed in roads. The central divider between the openings is removable for easier access.

Frame Size
1405mm x 800mm

Lid Size
548mm x 548mm

Weight
18.6KG

Loading
PEDESTRIAN ONLY

Material
GALVANISED STEEL

Compatibility
Will work with any brand of manhole cover and frame

Overview

We have designed the MuckStopper RS 1220 to solve the challenge of mud and silt entering 1220mm x 675mm manhole covers and blocking the drainage system below. This barrier protects the drains from silt whilst allowing access to the chamber below.

Rugged and easy to fit, we designed MuckStopper RS 1220 for you to install beneath the manhole cover and frame. It has a robust, silt-tight, removable lid to allow chamber access but prevent the ingress of silt and dirt.

MUCK STOPPER

INSTALLATION GUIDE **100mm** DEEP COVER

This guide is for installing the MuckStopper with a 100mm deep manhole cover and frame. Refer to our alternative guide when installing the MuckStopper with a 150mm deep frame.



1

Before installing the manhole cover & frame, install the MuckStopper, one course of bricks (or one precast section) below the frame. Bed the MuckStopper frame in place with mortar.



2

Install the next course of brickwork (or precast section) above the MuckStopper. Complete installation of the manhole cover and frame as per the manufacturer's guidelines above the MuckStopper.



3

At the end of the project, remove the MuckStopper and any debris it has collected, leaving the drains free of blockages.



4

Replace the manhole cover and frame and set final levels before surfacing as usual.

MUCK STOPPER

INSTALLATION GUIDE **150mm** DEEP COVER

This guide is for installing the MuckStopper with a 150mm deep manhole cover and frame. Refer to our alternative guide when installing the MuckStopper with a 100mm deep frame.



1

Before installing the manhole cover & frame, install the MuckStopper directly below the frame. Bed the MuckStopper frame in place with mortar and ensure it is level.



2

Place more mortar above the MuckStopper frame and complete the installation of the manhole cover and frame per the manufacturer's guidelines above the MuckStopper.



3

At the end of the project, remove the MuckStopper RS 675 and any debris it has collected, leaving the drains free of blockages.



4

With the MuckStopper removed, re-install the manhole cover and frame without it and set final levels before surfacing as usual.



USAGE INSTRUCTIONS

USING THE MUCKSTOPPER & ACCESSING THE MANHOLE

Perform regular checks to monitor silt levels on top of the MuckStopper.

To access the manhole chamber:

1. Remove the manhole cover and remove any build-up of silt on top of the MuckStopper using a suitable tool.
2. Carefully lift the MuckStopper lid off and place it on one side.
3. Before accessing the manhole, or inspection, complete a risk assessment and method statement in accordance with your site practice.
4. Wear adequate PPE and only enter if safe to do so.

TRANSPORTING MUCKSTOPPER UNITS WITH A FORKLIFT

Multiple MuckStopper RS 675 and RS 1220 units can be transported on a pallet using a forklift, telehandler or excavator forks. Follow typical safe working practices.

Individual MuckStopper RS 675 and RS 1220 units can be transported by hand, following safe manual handling and lifting practices to avoid injury.

SAFETY INSTRUCTIONS

A site-specific Risk Assessment, and lift plan, where applicable, must be completed by the responsible person before using this equipment to control risks, produce a safe system of work and ensure safety for you, your colleagues and others. Your risk assessment will determine the correct Personal Protective Equipment (PPE) for your task. You must use it. Drainfast recommends that you should wear:



Hard hat



Protective footwear (steel toecaps)



Safety glasses



Suitable clothing



Gloves

STORAGE

Store on a suitable flat surface

IMPORTANT SAFETY NOTES

- Read these instructions before using this equipment. If there is anything you do not understand or if you have any concerns, do not use this equipment. Contact your supervisor or Drainfast for advice.
- You must check that you have considered all the safety requirements for your task and that this equipment is suitable.
- You must protect bystanders and the general public by preventing access to the working area.

USAGE & TRANSPORTATION

- Make sure you know how to use this equipment and understand all aspects of its operation.
- Take care in confined spaces, near ceilings or similar hazards. This equipment was designed for vertical lifting. Do not drag or swing.
- Before operating this equipment, check that you have enough space to work safely and make sure that the working area is clear of hazards, obstructions and personnel.
- Before lowering MuckStopper units, make sure that the landing zone is clear and capable of accepting the size and weight of the load.
- Before lifting equipment, check that the load is secured, balanced and stable. Allow space for the equipment to move if the load shifts.
- Manoeuvre loaded or raised equipment carefully. Travel and turn slowly to prevent units from becoming unstable.

PERSONNEL

- All personnel must wear appropriate personal protective equipment.
- Do not wear loose clothing or jewellery, and tie back long hair to avoid becoming tangled or trapped in this equipment. You must make everyone in the work area aware of your actions.
- All personnel involved in the lifting operation must be competent to do so and must

have been briefed in conjunction with this User Guide available from Drainfast, the manufacturer.

- Do not use this equipment if you are tired, unwell or under the influence of alcohol or drugs. You should inform your supervisor if you are taking any medication or undergoing treatment.
- All personnel involved in lifting and transporting this product must have read this User Guide and be properly briefed.
- You must be competent, alert and medically fit when using this equipment. If you have a medical condition or a mental or physical disability, you must seek advice from a medical professional before using this equipment.

EQUIPMENT MAINTENANCE & CLEANING

- Remove any excess silt from the MuckStopper RS 675 and RS 1220 with a suitable tool. If available, use a pressure washer to remove a build-up of silt from the MuckStopper.

- A competent person must inspect this equipment before each use and then regularly, as determined by your risk assessment or working practice. If you are concerned about its condition or suitability, refrain from using it.

MODIFICATIONS

Modifications and alterations to the product are strictly prohibited.

Drainfast operates a continuous improvement policy and therefore reserves the right to alter technical specifications and user guide details at any point without notice.

Drainfast and/or their directors, employees, insurers or recognised agents will not be held liable for consequential damages, losses or expenses relating to the inability to use the product correctly for its purpose.



01420 555600
action@drainfast.co.uk
www.drainfast.co.uk

Drainfast Ltd
Vision Park, Selborne Road, Alton, Hampshire, GU34 3HL

Copyright © 2022 Drainfast Ltd. All Rights Reserved.

MuckStopper User Guide - Issue 1